



**PRECISION IN - LINE COLOUR PICTURE TUBE
TECHNICAL SPECIFICATION**

A 68 QCP 893 X 432

(100Hz)

- tentative -

SAMSUNG SDI Germany GmbH

BERLIN - GERMANY

CONTENTS

ITEM	PAGE
Customer's Acceptance.....	3
1. Description.....	4
1.1. General Data.....	4
1.2. Parameter.....	5
2. Limiting Values.....	6
3. Operating Parameters.....	7
4. Convergence Characteristics (Misconvergence).....	11
5. Geometry characteristics.....	13
6. Screen Quality.....	15
6.1. Evaluation.....	15
6.2. Admitted Failures.....	16
7. Electrical Values of the Deflection Yoke and SVM - Coil.....	17
8. Mechanical Outline Drawing.....	18
9. General Technical Conditions.....	19
9.1. Climatic resistance.....	19
9.2. Transport and storage.....	20
10. Mounting and Operating Instructions.....	21
10.1. General Remarks.....	21
10.2. Mounting and Operating Instructions.....	22



(TENTATIVE)

A 68 QCP 893 X 432

**REVISE
05 / 01**



CUSTOMER'S ACCEPTANCE SPECIFICATION

COLOUR PICTURE TUBE

MODEL: **A 68 QCP 893 X 432**

(B_v:mG ; B_h:mG)

Remarks:

This specification is approved and confirmed by

.....

and

SAMSUNG SDI Germany GmbH

Proposed by:

Approved by:

.....

.....

General Manager
Quality Assurance Department

Signature

Date:

Date:

Please return one specification after your approval.

1. DESCRIPTION

The logo consists of the word "SAMSUNG" in white, bold, uppercase letters inside a blue oval. Below the oval, the letters "SDIG" are written in blue, uppercase letters.	PAGE 3	of 25
--	----------------------	---------------------

The tube **A 68 QCP 893 X 432** is an In-Line-Colour-Picture-Tube (29 inch (27V) 110 degree) with a faceplate made of clear glass with dark coating.

The shadow mask is a slot mask. The deflection yoke and the magnetic correction system are firmly integrated components of the tube.

The A68 is an infinite flat square colour picture tube with 4:3 aspect ratio.

Type designation and standard type variation example of picture tube:

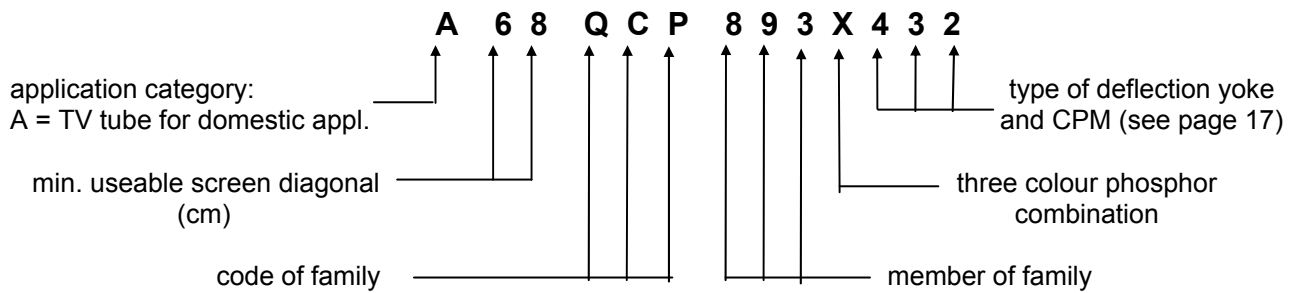

1.1. General Data

Screen blackstripe luminescent screen

Panel transmission in the centre of the screen 45% including dark coating

Superpigmented red and blue phosphor

Focusing Electrostatic

Focus lens Uni-Bi - potential focusing

Deflection Electromagnetic, firmly integrated deflection yoke

Neck diameter 29,1 mm



In - Line electron gun

Quick heating cathodes

Purity and static convergence optimal adjusted

Dynamic convergence correction free

Protection against high-voltage arcing by high ohmic internal layer

Internal magnetic shielding

Protection against implosion

Saddle - Toroidal Yoke (N - S pincushion correction free)

Tinted phosphor screen for improved contrast

Low expansion Invar shadow mask

Anti - static coating

1.2. Parameters

Distance between the centre of adjacent phosphor triplets in the centre of the screen	mm	H 0.76 V 0.62
Useable screen diagonal	mm	676.0
Useable screen width	mm	540.8
Useable screen height	mm	405.6
Screen area	cm ²	2193
Deflection angle diagonal		110 °
Deflection angle horizontal		93 °
Deflection angle vertical		74 °
Weight	kg	ca. 37

2. Limiting Values

Heating Voltage	U_f	For optimum operating time, 6.3 V should be maintained as precisely as possible. Permanent deviations by 0.15 V are not critical. The limit is $\pm 5\%$. This is allowed only temporarily; the long - term mean value should be within ± 0.15 V.
Anode Voltage	U_a max.	33 kV (absolute limiting value)
	U_a min.	25kV
Long - term Average Anode Current	I_a max.	1.8 mA
Focusing Voltage	U_{G3} max.	9.9 kV
Grid 2 Voltage	U_{G2} max.	1.2 kV (included video signal)
Cathode peak voltage (against grid 1)	$(-U_K)_s$ max.	2 V
	U_K s max.	400 V
Cathode Voltage (against grid 1)	$(-U_K)$ max.	0 V
	U_K max	200 V
Cathode peak Voltage against heater Heater negative with regard to cathode		
During equipment warmup period not exceeding 15 sec.	U_{-fK} s max.	450 V
After equipment warmup period	U_{-fK} s max.	200 V
Cathode Voltage against heater Heater positive with regard to cathode		
AC component value	U_{+fK} max.	200 V
DC component value	U_{+fK} max.	0 V

3. Operating Parameters

Unless otherwise specified, the following is valid:

1. Anode Voltage $U_a = 30 \text{ kV}$
2. Heating Voltage $U_f = 6.3 \text{ V}$
3. All Voltages refer to grid 1.
4. Grid 2 Voltage $U_{G2} = 600 \text{ V}$ to 1100 V for Cutoff Cathode Voltage of 180 V .
5. Focussing Voltage optimal adjusted
6. Colour Coordinates : $x = 0.313$ and $y = 0.329$ for EBU - white D65 (6550 K).
7. A heating time of ten minutes at least before testing is necessary.
8. Ambient light: 5 lx to 10 lx
9. Measurement direction: Facing to East.
10. The deflection field should be applied for all tests.

Parameter	Adjusting Value	Limiting Value
Heating Current	$U_f = 6.3 \text{ V}$	$I_f = 0.305$ to 0.365 A
Leakage Current Heater / Cathodes	Connect grids 1; 2; 3 with the cathode of each gun to be measured and apply $\pm 200 \text{ V}$ with respect to the heater; $U_a = 0 \text{ V}$	max. $\pm 30 \mu\text{A}$
Heating Time	$U_f = 6.3 \text{ V}$; internal resistance of the voltage source $< 0,1 \text{ Ohm}$ (constant voltage source with current limitation $> 6 \text{ A}$) The time is measured between start of heater and the appearance of a clearly recognizable picture: defocussing is still allowed. The other adjustments of the tube correspond to its use in TV set with central position of the controllers for contrast and brightness.	max. 8 sec.
Anode Leakage current	$U_a = 33 \text{ kV}$ $U_{G2} = 200 \text{ V}$ $U_{G1} = -150 \text{ V}$ $U_k = 0 \text{ V}$	max. $\pm 45 \mu\text{A}$
Grid 3 leakage current	$U_a = 33 \text{ kV}$ $U_{G2} = 200 \text{ V}$ $U_{G1} = -150 \text{ V}$ $U_k = 0 \text{ V}$	max. $\pm 15 \mu\text{A}$

(TENTATIVE)

A 68 QCP 893 X 432**REVISE
05 / 01**

Grid 2 leakage current	$U_a = 33 \text{ kV}$ $U_{G2} = 650 \text{ V}$ $U_{G1} = -150 \text{ V}$ $U_k = 200 \text{ V}$	max. $\pm 5 \mu\text{A}$
Grid 1 leakage current	$U_a = 33 \text{ kV}$ $U_{G2} = 200 \text{ V}$ $U_{G1} = -150 \text{ V}$ $U_k = 0 \text{ V}$	max. $\pm 5 \mu\text{A}$
High Voltage Arcing	$U_a = 33 \text{ kV}$ $U_{G2} = 200 \text{ V}$ $U_{G1} = -150 \text{ V}$ $U_k = 0 \text{ V}$	max. 2 in 1 min. max. 5 in 15 min. no accumulation
Stray Emission	$U_a = 33 \text{ kV}$ $U_{G2} = 200 \text{ V}$ $U_{G1} = -150 \text{ V}$ $U_k = 0 \text{ V}$ Horizontal and vertical deflection or only horizontal deflection switched on.	no brightening; ambient lighting less than 1 lx.
Focusing Voltage	$U_a = 30 \text{ kV}$	26.0 to 30.0 % U_a
Cathode Cutoff Voltage R, G, B	No vertical deflection. Apply positive voltage with respect to grid 1 to the three cathodes; apply G_2 voltage between 300 V and 1000 V; adjust the voltage of the test cathode for slight appearance of the horizontal line of the respective colour. Use the same procedure with the other cathodes.	see Fig. 2
Ratio of Cutoff Voltages	Calculate the ratio between the resulting cutoff voltages.	max. 1.25
White light output Anode Current	$80 \text{ cd} / \text{m}^2$ 6550 K + 7 M.P.C.D. or 9300 K + 27 M.P.C.D.	max. $1000 \mu\text{A}$ (screen transmission 45%)
White Uniformity	for $I_a = 1800 \mu\text{A}$; test picture is white screen 6550 K + 7 M.P.C.D. . Distance of observation 2 m.	no distinct colouring in white visible
Colour Purity	Adjust like for white uniformity but only one colour R,G,B switched on respectively. Distance of observation 2 m.	no external colour visible with the naked eye.

(TENTATIVE)

A 68 QCP 893 X 432**REVISE
05 / 01**

Percentage of total anode current supplied by each beam for white light	U _a = 30 kV red: green: blue:	6550 K 42 % 33 % 25 %	9300 K 34% 36 % 30 %
X - Radiation	U _a = 30 kV I _k = 1.3 mA		<1 μSv / h in a distance of 100 mm
Capacitance grid 1	between grid 1 and all other electrodes		about 14.0 pF
Capacitance Cathode	between all cathodes and all other electrodes		about 12.0 pF
Capacitance grid 3	between grid 3,5 and all other electrodes		about 4.5 pF
Capacitance Anode	between anode and external conductive coating including metal hardware		2200 pF to 2900 pF
Resistance of the external conductive coating	Resistance between two measuring points with a distance of 25.4 mm measured with ball - shaped contacts r = 12.5 mm		max. 400 Ohm
Resistance between metal hardware and external conductive coating			min. 50 M Ohm
Raster centre displacement	measured in the centre of the screen		horizontal: 0 ± 5 mm vertical: 0 ± 5 mm

Fig.1: Typical Drive Characteristics

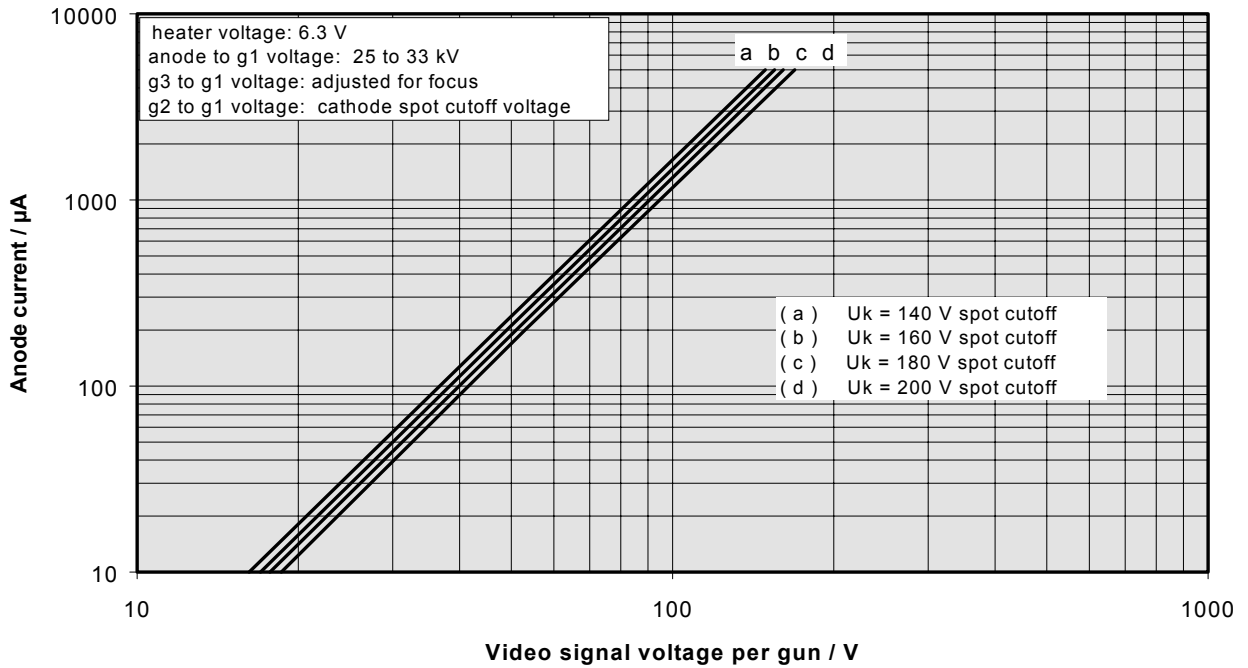
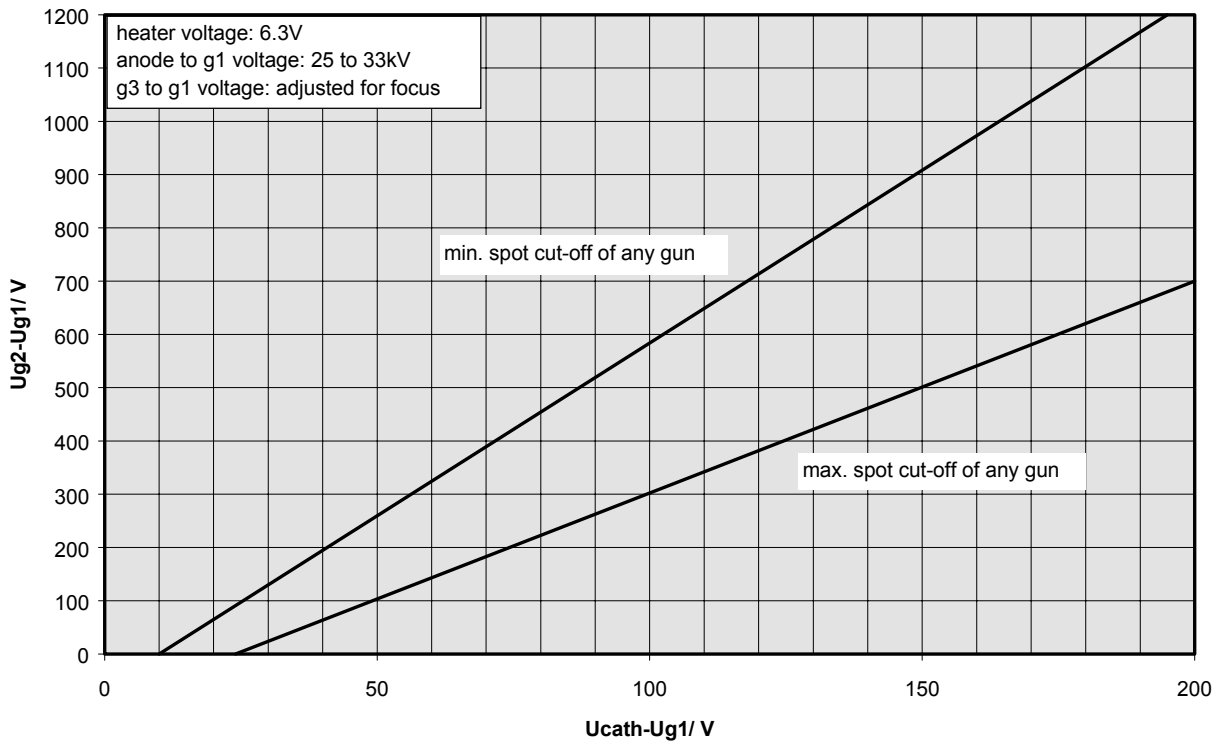

Fig.2: Cut-off Design Characteristic



4. Convergence Characteristics (Misconvergence)

Control Conditions:

1. $U_a = 30 \text{ kV}$;

Use „Dot and Cross Hatch“ pattern, adjust optimal focus at a specified point on the screen at about $180 \mu\text{A}$.

2. Preheat for 15 minutes at least before convergence measuring. Write out screen fully, screen in direction East, de - magnetize colour picture tube before each measuring.

The indicated maximum values are defined as the distance between centres of the red, blue and green beams at the screen. The centre is defined as the midpoint of the brightest portion of the beam.

Fig. 3

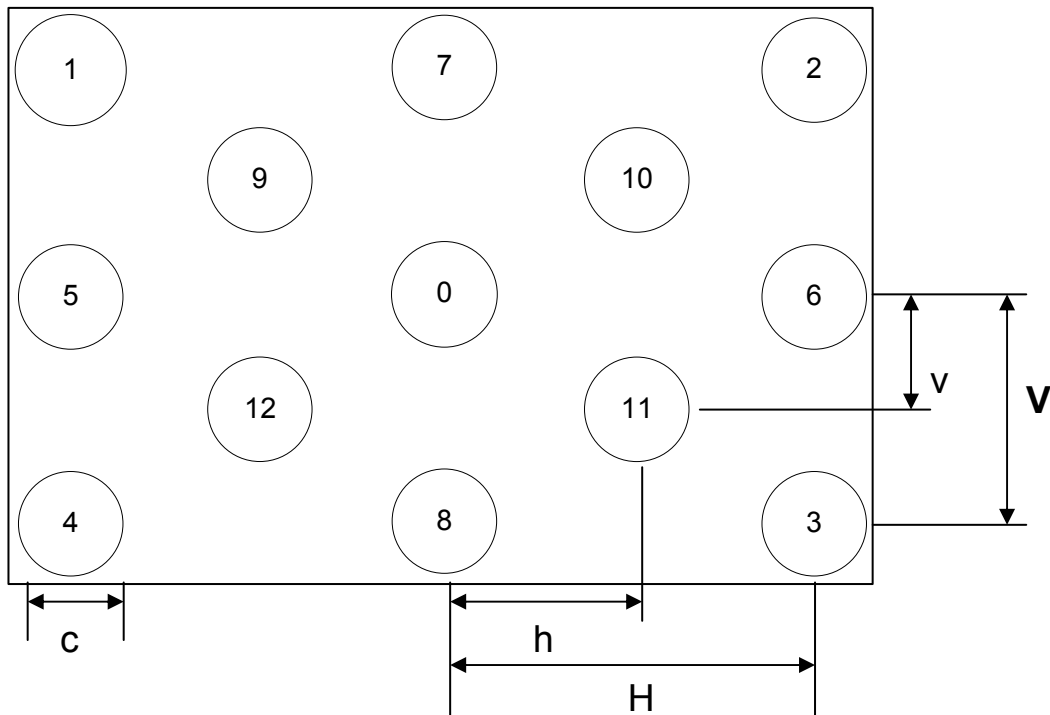

(TENTATIVE)

A 68 QCP 893 X 432

REVISE
05 / 01

Position of measuring points on the screen

Distance of measuring points (mm)

H (2h = H)	250
V (2v = V)	185
c	10

Admissible misconvergence in X - and Y - direction (mm)

Measuring points		misconvergence
Centre	0	0.4
Corner points	1 ; 2 ; 3 ; 4	1.8
Medium points	9 ; 10 ; 11 ; 12	1.4
right, left	5 ; 6	1.2
top, bottom	7 ; 8	1.2

5. Geometry characteristics

Use „Cross Hatch“ pattern, only green colour.

Positioning of the picture tube: screen to East

De - magnetize the colour picture tube before measuring and after each change of position.

All deviations are to be related to the square with the following values

Measurement with electronic east-west correction

Fig. 4

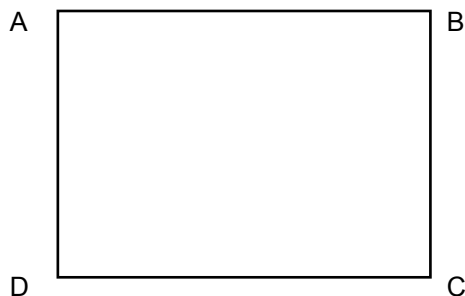

Distance	Measuring frame dimension (mm)
AB ; CD	510 ± 5
AD ; BC	380 ± 5

Raster Distortion

For all kinds of raster distortion (pincushion, barrel, trapezium, parallelogram, rotation,..) is valid: A matched tube/DY-coil combination should fall within an area, defined in Fig. 5.

Fig. 5

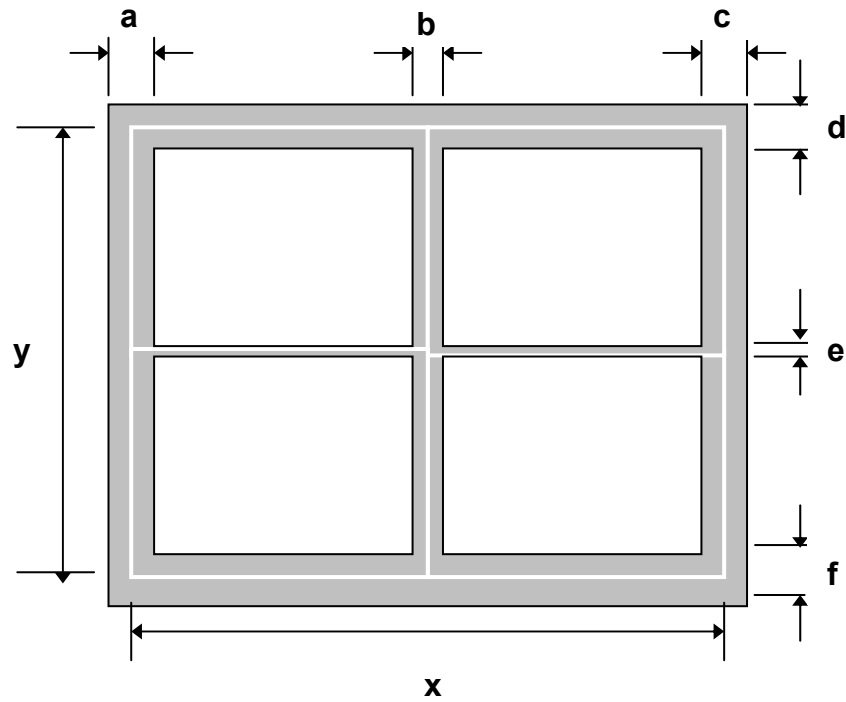

Item	x	y	a	b	c	d	e	f
Value / mm	510	380	6	5	6	6	3	6

6. Screen Quality

6.1. Evaluation

The screen quality is evaluated visually when screen is both excited and not excited.

Excited screen: switched on blank raster with a white light intensity of 50 cd / m^2 , ambient lighting less than 5 lux.

Control of not excited screen with an ambient lighting of 700 to 1000 lux.

A rectangle around the screen centre is zone A

Size of zone A	
a	270mm
b	213 mm

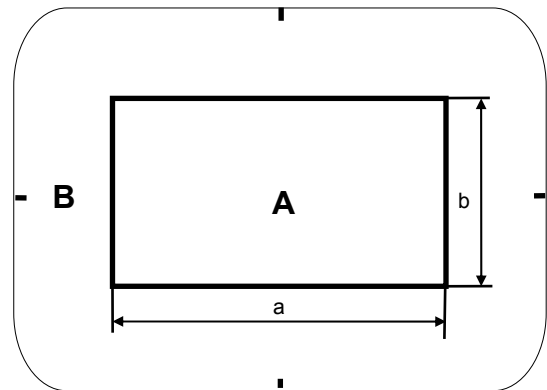

The remaining area of the useable screen field is zone B.

The visibility of a failure in the glass or in the screening is evaluated by observing various transmissions through colour-neutral filtering glass with a distance of observation of 1.5 m.

High - Contrast Failures:

These failures are visible through filtering glass of 0.70 and, in comparison also visible through a filtering glass of 1.30.

Medium - Contrast Failures:

These failures are visible through filtering glass of 0.7 but in comparison not visible through filtering glass of 1.30.

6.2. Admitted Failures

	PAGE 15	of 25
---	------------	----------

screen blemishes

Failuresize (mm)	high contrast			high contrast and medium contrast		
	zone A	zone A + B	min. seperation	zone A	zone A + B	min. seperation
> 2.0	0	0	-	0	0	-
1,6 - 2.0	0	0	-	0	2	80 mm
1,0...<1,6	0	0	-	1	2	80 mm
0.7...< 1.0	1	3	80 mm	2	6	80 mm
0.5...< 0.7	2	4	50 mm	4	8	50 mm
0.25...< 0.5	3	8	50 mm	6	10	50 mm
< 0.25	The number of failures is not limited unless distinct cloud formation or discolouration are visible from a distance of 1 m					

glass scratches

width (mm)	length (mm)
≤ 0.05	ignore
$0.05 \dots \leq 0.10$	40
$0.10 \dots \leq 0.15$	10
> 0.15	no allowed

7. Electrical Values of the Deflection Yoke and SVM-Coil

	PAGE 16	of 25
---	------------	----------

DY-name: W-2920E

SVM -name (with CPM): 291P-20

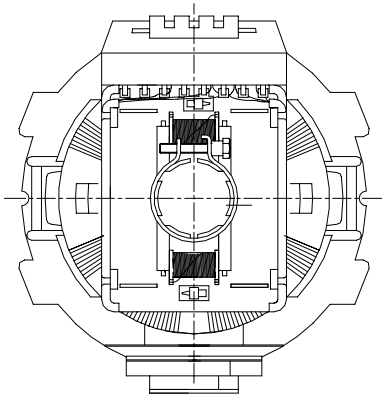

TERMINAL BOARD

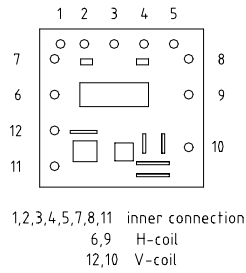

HORIZONTAL COIL

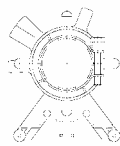
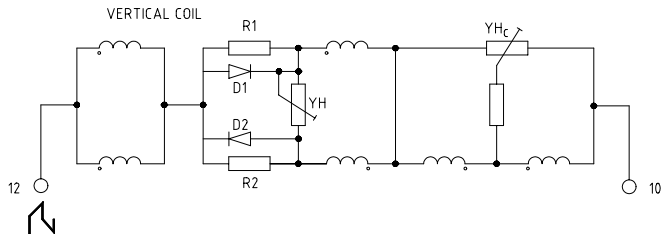
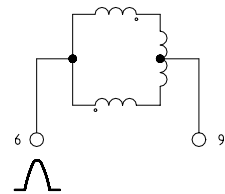

3.6x4
W=1
W=1

Coil	Parameter	Unit	Value
Horizontal deflection	Inductivity for 1 V rms and 1 kHz	mH	0.31 ± 7 %
	DC resistance for 25 °C	Ohm	0.37 ± 10 %
Vertical deflection	Inductivity for 1 V rms and 1 kHz	mH	7.34 ± 10 %
	DC resistance for 25 °C	Ohm	5.13 ± 10 %
Scan Velocity Modulation	Inductivity	μH	7.20
	DC resistance for 25 °C	Ohm	0.24

8. Mechanical Outline Drawing



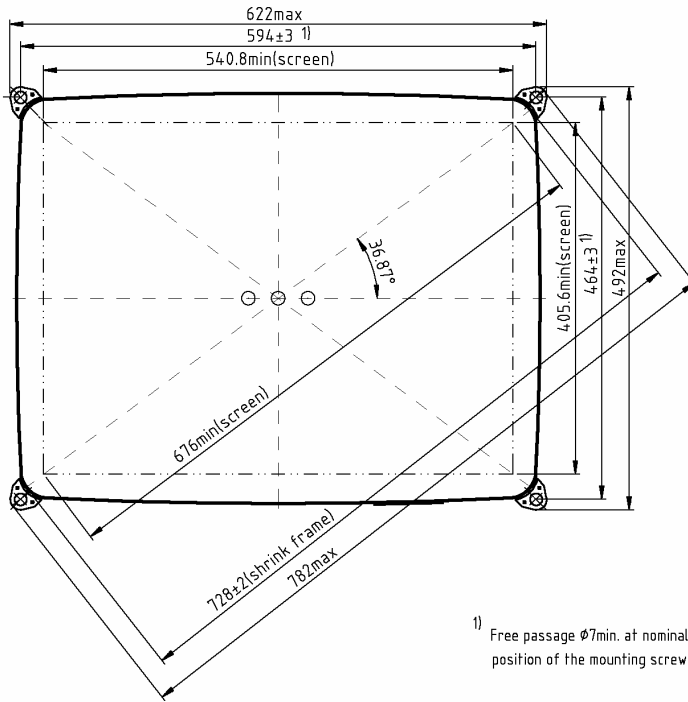
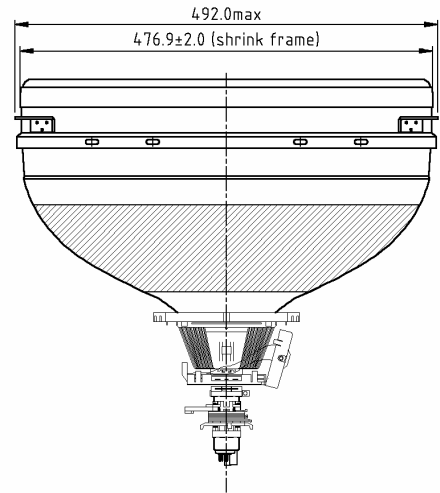
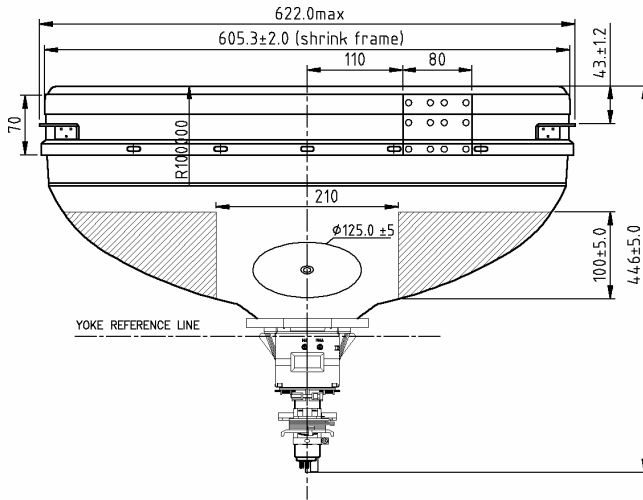

1) Free passage φ7min. at nominal position of the mounting screw

anode contact

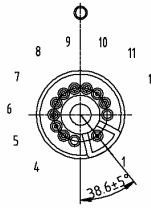

TUBE BASE
EIA NO.B10-277

PIN CONNECTIONS

- 1 GRID NO. 3
- 4 IC (PIN 5)
- 5 GRID NO.1
- 6 CATHODE OF GREEN BEAM
- 7 GRID NO.2
- 8 CATHODE OF RED BEAM
- 9 HEATER
- 10 HEATER
- 11 CATHODE OF BLUE BEAM
- 12 IC (PIN 11)

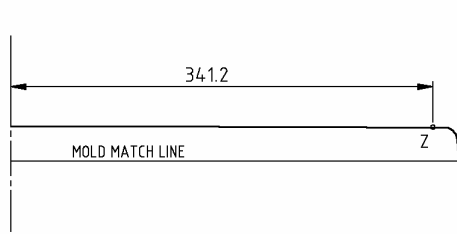

The Z reference point is located on the outside surface of the face plate on the diagonal screen axis respectively.
Coordinates for z-point: x=272.96 ; y=204.72 .

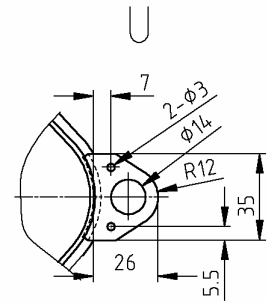
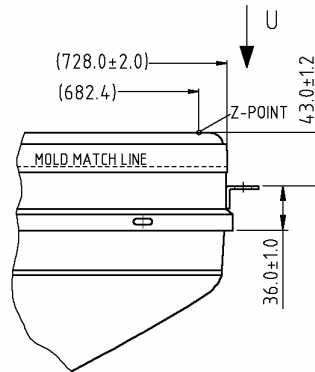

9. General Technical Conditions

9.1. Climatic resistance

Colour picture tubes must not be used close to aggressive media affecting their quality.

Ambient temperature:

At hottest position of the bulb - the tube neck - a maximum surface temperature of 90 °C must not be exceeded. The maximum surface temperature within the field of the metal inside cover sheating is 70 °C.

Relative air humidity: 80 %
 temperature: 20 °C
 atmospheric pressure: 86 to 106 kPa

} mean monthly values for hottest and most humid periods

9.2. Transport and storage**Storage:**

As packed by the producer, colour picture tubes can be stored for three years at least under the following conditions:

- Ambient temperature: 5 °C up to 35 °C
- Relative air humidity: max. 80 %
- max. admissible ambient temperature to be linked with it: 25 °C

Transport:

Within the period of storage, colour picture tubes can be transported in the original package or already installed.

Transport conditions must be in line with storage conditions. Over a period of one month, the ambient temperature can be between -20 °C and +40 °C within the period of storage.

Impact load on colour picture tubes must not exceed 30 g. The rooms of transport and storage must be free of aggressive media.

Indications:

Content of Information	marked on	
	picture tube	transport package
Producer or trade mark of producer	X	X
Type designation	X	X
Date of production (week and year)	X	-
Number of manufacturing	X	-
Warnings, Implosion danger	X	-
Marking of package for transport	-	X

The date of shipment is indicated in the shipping documents.

10. Mounting and Operating Instructions

	PAGE 20	of 25
---	------------	----------

10.1. General Remarks

Colour picture tubes have always to be stored and transported in their original package.

The position for transport (screen vertical position, anode contact upwards) and the indicated mechanical and atmospheric limiting values must be kept.

When unpacking the tube must be held near the implosion protection or mounting lugs but not at the neck or the deflection yoke. When handling unpacked tubes, the face must be protected and coarse non - skid protective gloves must be put on. When moving the tubes for a short time, they should be in mounting position and the screen downwards.

Unpacked tubes must always be placed on clean, soft material (plastic foam, rubber band etc.) with screen side downwards; this is also necessary with screen protective sheeting. Protect the picture tubes against blows, impacts or scratches.

The deflection unit and the purity convergence magnets are integrated parts of the picture tube. With great technical expertise they were adjusted perfectly and fixed solidly by the producer of the picture tubes. Any subsequent change in these construction units by user is not allowed. This makes claims under guarantee invalid. The after - adjusting of individual tubes by the producer is not possible.

The screen must be cleaned by means of slightly damped soft piece of cloth and non - scratching glass detergent.

In case of low temperatures during storage or transport, a time of two hours should pass before putting the picture tube or the TV set into operation in order to avoid damage caused by humidity - conditioned high - voltage sparkovers.

The guarantee for the tube covers usual TV application. In case of another usage, data control devices etc. in particular, the consent of the producer must be obtained before.

When operating picture tubes that had worked before, the fact has to be taken into account that charges between anode and external conductive coating or the internal conductive coating may exist long time after switching off the operating voltages. Therefore the anode contact is to be short - circuited with the external coating of the tube and the metal frame for one minute at least before the tube out of the TV set.

10.2. Mounting and Operating Instructions



The tube is to be fixed on the set only by means of the four mounting lugs. When installing the tube the screen part of the tube must not stick in the set and there must not be considerable bending powers at the mounting lugs. If necessary, the level of the four supporting points has to be adjusted to the level of the mounting lugs by means of adjustable counterscrews.

The fixing of further construction units at the tube may consist of the fixing of the demagnetizing coil(s) and the spring pull contact for the zero potential connection of the conductive external coating and the implosion protection. When using a combined socked - PCB the admissible weight included the construction elements fixed is max. 100 g.

The connections to the deflection yoke, the tube base and the anode must be flexible.

For set design measured values on individual tubes must not be used. In every case tolerances given by the producer have to be taken into account.

The operating values as indicated in the data list must not be exceed even under most unfavourable operating conditions (voltage fluctuations, climatic influences, construction unit tolerances etc.).

If the limiting values are exceeded, claims under guarentee will become invalid.

The temperature of the cathode greatly influences the service - life of the tubes. Therefore the heating voltage nominal value should be kept as precisely as possible with taking line current fluctuations, voltage drops and the kind of voltage into account. The heating voltage tolerance as indicated in the data list is a only minimum request.

When using the tube, it has to be in a horizontal position with the anode contact upwards. Deviations of ± 30 °C are allowed. Other positions have to be indicated to the producers before usage.

To avoid burning - in phenomena on the screen, a fixed picture with a very high beam current must not remain over a long time (cross hatch pattern for example).

For the same reason, the time constants for electrical supply of cathodes, G1 and G2 and deflecting circuit have to be fixed so that before the end of deflection, the high voltage is reduced to a value that does not allow intensive lighting points any more. The free room round the deflection yoke and PCM as indicated in the dimension pictures must be free of electrical and / or magnetic affective material like metal sheet, for example. The same applies to a production field round the tube cone. A distance of ≥ 30 mm must be kept in order to avoid the distortion of magnetic field of correction magnets that may be on the cone.

Despite through manufacturing, high voltage discharge may occur between the anode and other electrodes. The peak current of these discharges is limited owing to a specific tube technology. Despite this fact it is necessary to install preresistance ≥ 1 k Ohm in the lines to the cathodes and grids 1, 2 and 3 and to protect the above mentioned electrodes through protective spark gaps. The discharge values of these voltage dischargers should be 10 to 12 kV for G3 and 1 to 2 kV for all the other electrodes. The zero potential of spark gaps is to be connected with the conductive external coating of the picture tube and the circuit with a resistance and inductivity as low as possible.

The contact to the external conductive coating of the tube should be made at several positions of the bulb under spring pressing.

The contact to the metal frame can be made either trough a moving hook fixed in the brass staple of the frame or trough a solder tag screwed when the tube is fixed. In this case a tooth lock washer has to be installed between the solder tag and the mounting lug of the tube.

The metal frame of the implosion protection is insulated from the external contacting of the tube but it has it's own considerable capacity. To avoid static charges the frame should have zero potential in the set. When the chassis is connected with the line current and the frame can be touched, we recommend to connect the frame trough coupling in parallel 2 Mohm / 4,7 nF with the external conductive coating.

The voltage between the heating filament and the cathode has to be as low as possible. This applies to the alternating voltage component in particular. It is to avoid undersired modulations of brightness of the beam current.

A galvanic connection of 1 MOhm must exist between the cathode and the heating filament. When operating the set direct current connection between the other electrodes in the tube and the cathode is also to be maintained.

The necessary protection of the tube against the magnetic field of the earth or similar effects is made trough an iron shield within the tube. To ensure full efficiency of this shield demagnetizing must be made from time to time. A recommended value of degaussing power is 1700 peak to peak ampere turns minimum. For proper degaussing the current value after 5 cycles should not be less than a half of initial inrush current value. The steady state value in the coil due to the degaussing power source should not exceed 2.0 peak to peak ampere turns.

WARNING

X - Radiation:

Operation of this picture tube at abnormal conditions which exceeds the 0.1 μ S/h isoexposure - rate curve shown in figure 6 may produce soft X - rays which may constitute a health hazard on prolonged exposure at close range unless adequate external shielding is provided. Therefore, precautions must be exercised during servicing of TV receivers employing this tube to assure that the anode voltage and other tube voltage are adjusted to the recommended values so that the design maximum ratings will not be exceeded. This picture tube incorporates integral X - radiation shielding.

Figure 6

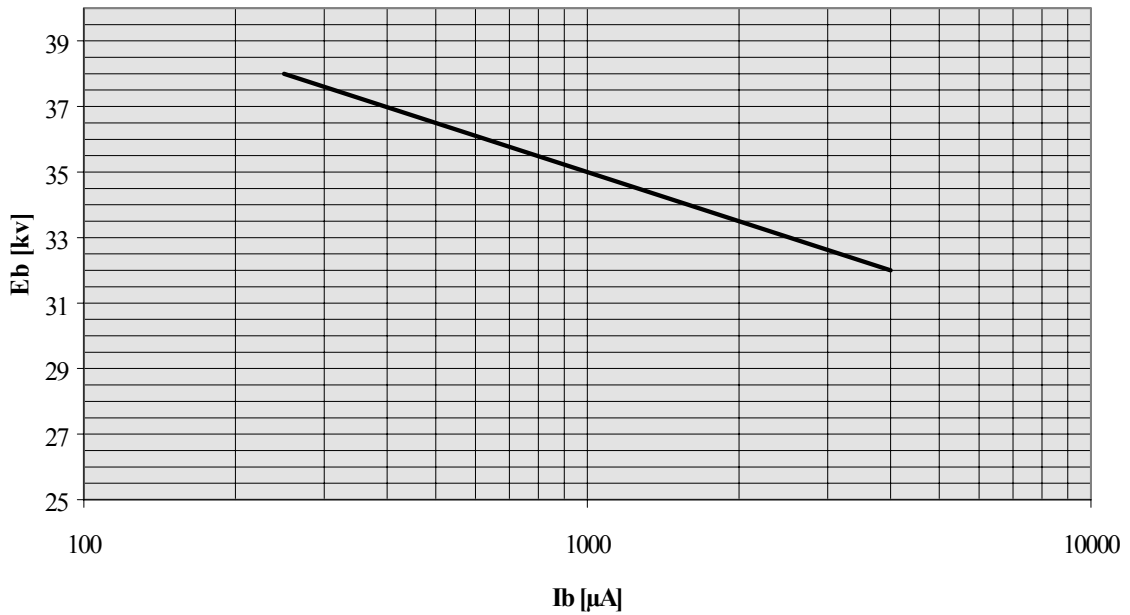

iso-exposure-rate limit curve for 1 μ Sv/h

MARKING

Label

MARKING SPECIFICATION

